

ASSEMBLY INSTRUCTIONS RSEAT B1

Thank you for choosing RSEAT. This instruction is developed to assist you in assembling of RSEAT B1.

⚠ WARNINGS

Before you begin assembling this simulator, please read all installation instructions and warnings thoroughly.

FAILURE TO COMPLY WITH OR OBSERVE ALL ASSEMBLY, SAFETY AND OPERATION INSTRUCTIONS AND WARNINGS REGARDING THE USE OF THIS PRODUCT MAY RESULT IN SERIOUS BODILY INJURY.

This simulator complies with the prescribed safety regulations. Inappropriate use may cause damage to persons and simulator.

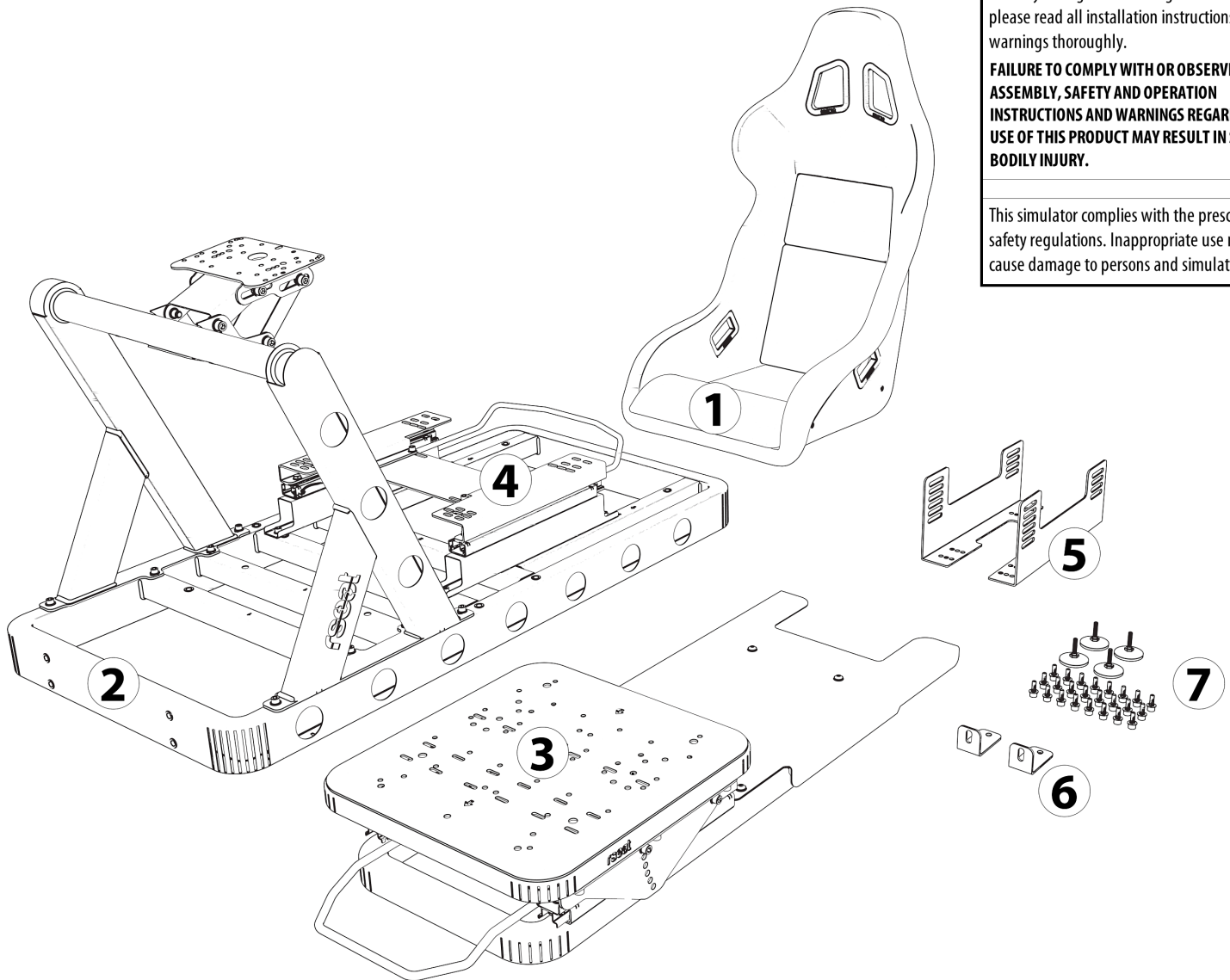

What's Included

- ① Racing Seat
- ② B1 Chassis including wheel console and wheel mount assembly attached
- ③ B1 Pedal Assembly including sliders
- ④ B1 Seat mounting assembly including seat sliders
- ⑤ B1 seat mounting brackets (left and right)
- ⑥ Pedal Assembly mounting brackets
- ⑦ Hardware: 16xM6x16mm, 8xM8x20mm, 4xM8x30mm, 4xM8x20mm Hex Screws, 5mm/6mm/8mm Hex Keys, 13mm wrench (x2)

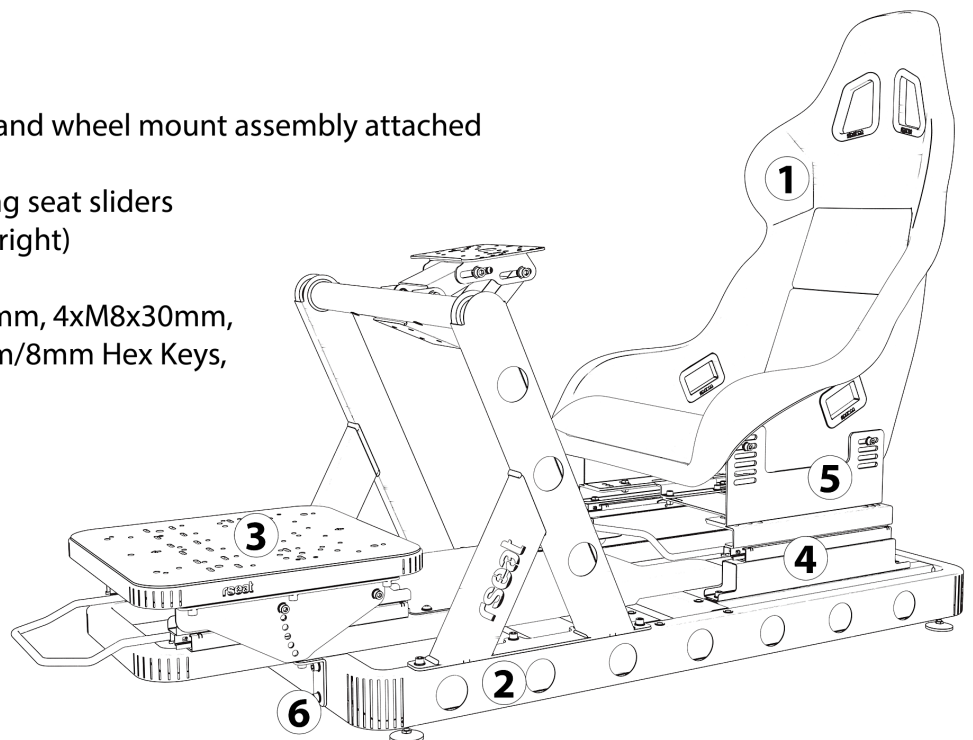

RSEAT B1 come in single box with dimensions: 127 x 63 x 68cm (50 x 24.8 x 26.8 inch)

BOX 1 of 1

1 Remove all the transport packaging including carton protection and Stretch wrap film.

- 2** 2.1 - Remove transport screws 2 x M8 x 20mm with the 6mm HEX Key provided
2.2 - Remove B1 Seat mounting assembly (4) from chassis (2)

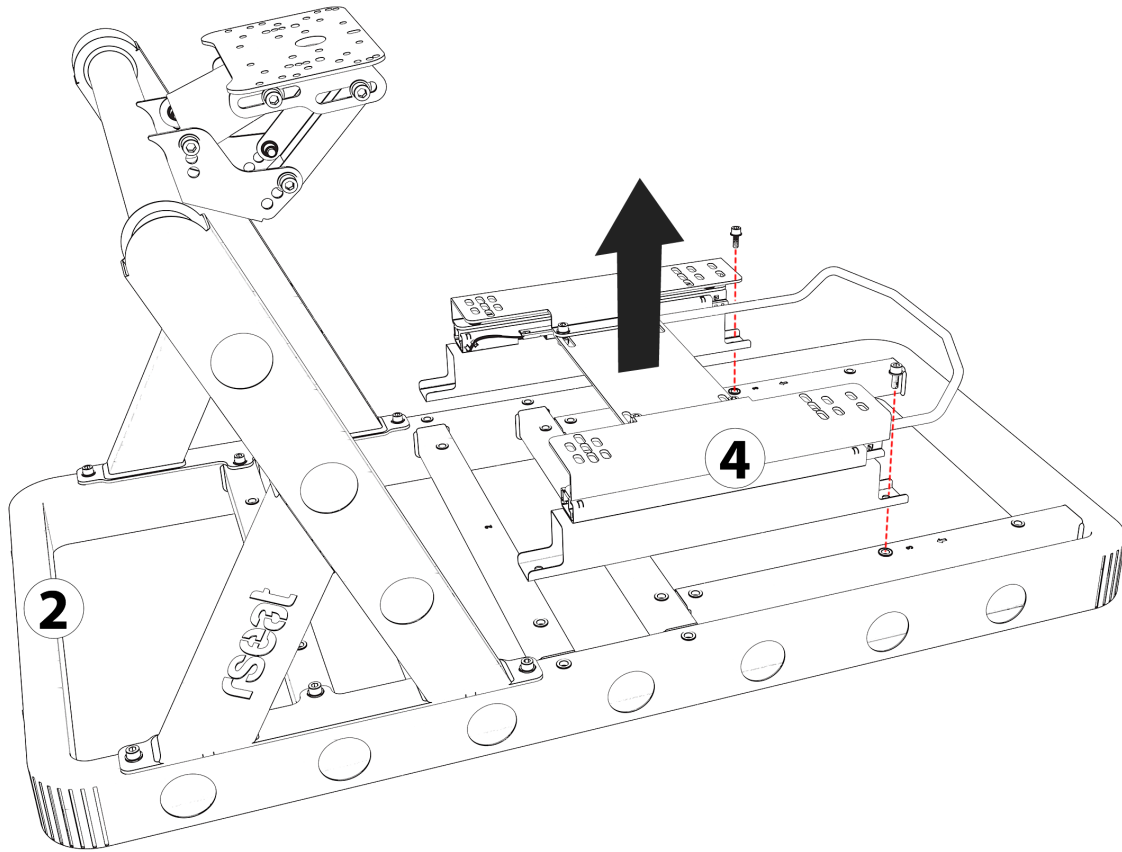

- 3** Install the 4 x foot steps (M8 thread) to B1 chassis (2). Use 10mm wrench to adjust chassis level to the floor.
IMPORTANT! Screw the foot steps to the bottom of the chassis by hand (do not tighten with the wrench before the final adjustment of your B1 chassis with all component assembled.)

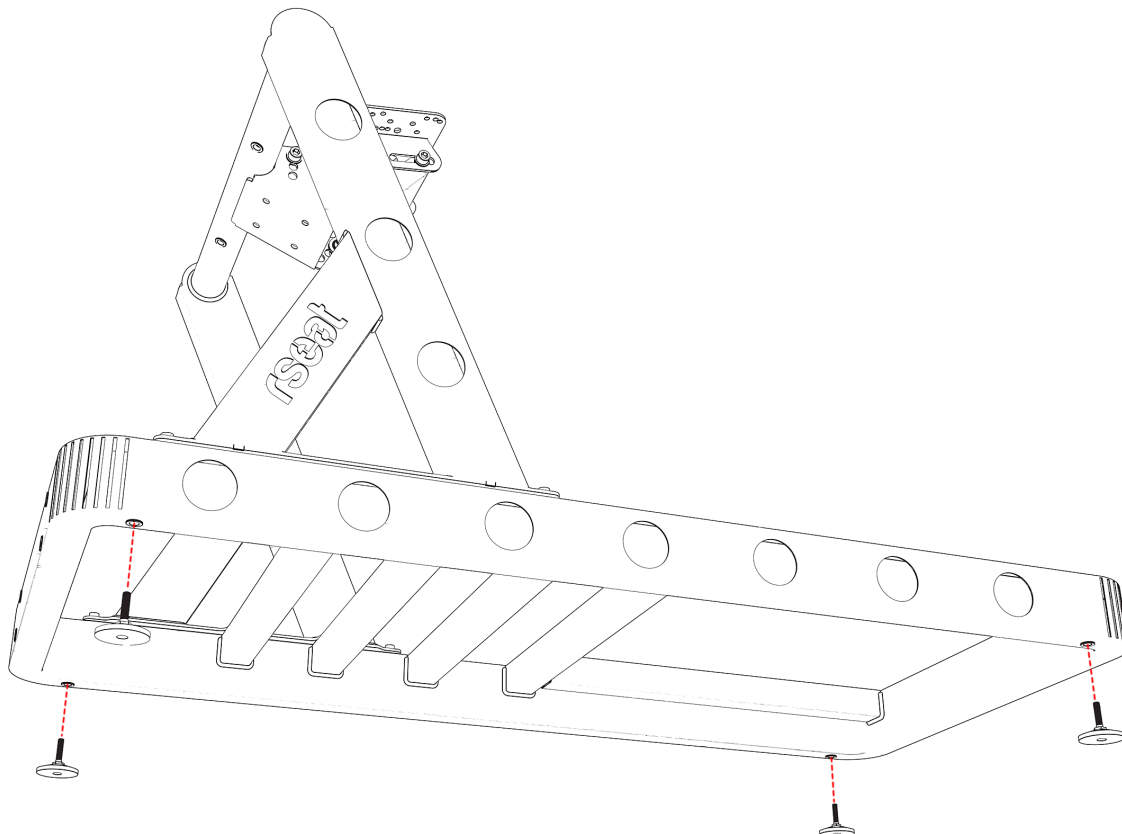

3**B1 Pedal assembly (3)**

Remove the 4 screws M8 x 20mm (2 per side) with the 6mm HEX Key provided with the assembly. Remove the Aluminum cover.

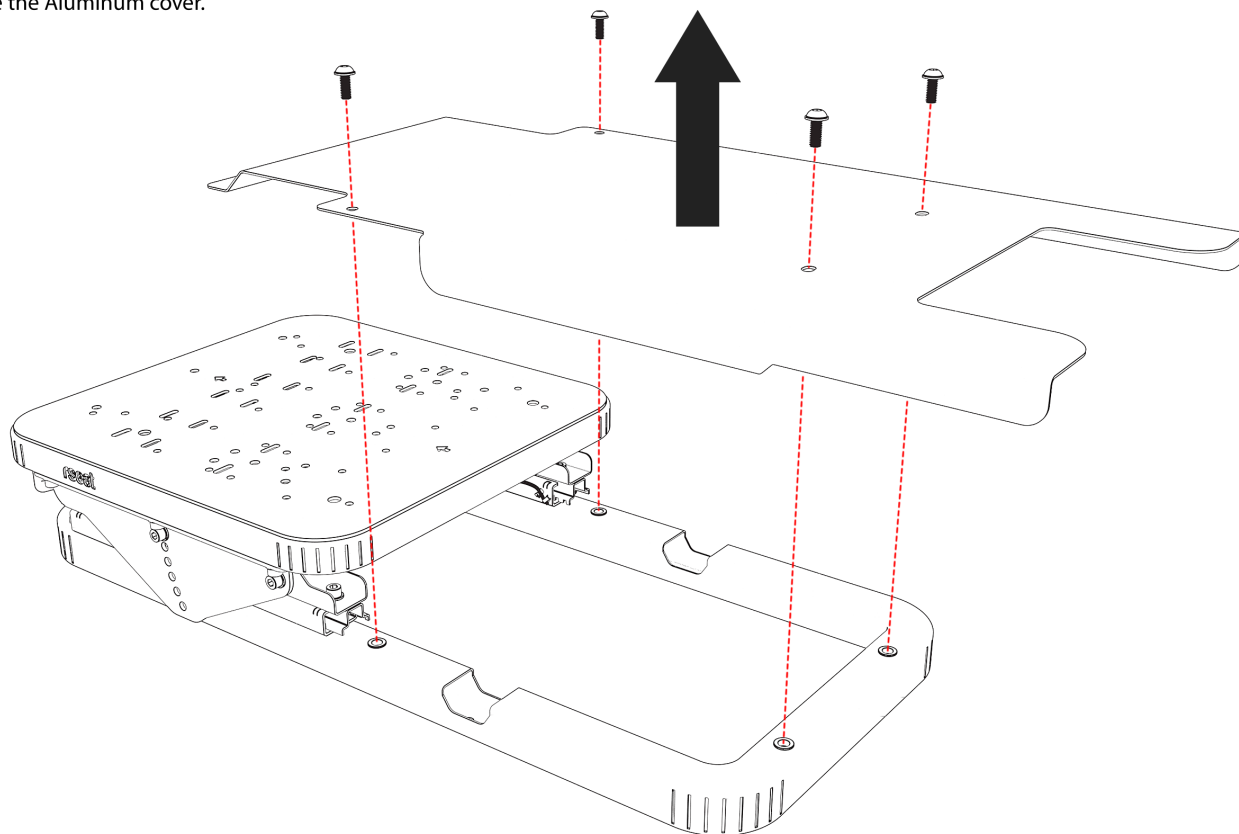
**4**

Install the Pedal Assembly (3) to the chassis (2) using 8 x (M8 x 20mm) screws.

Two screws from (back-top) and six from (bottom-front with mounting brackets (6))

Use the 6mm HEX Key provided with the assembly.

Install as shown on the image.

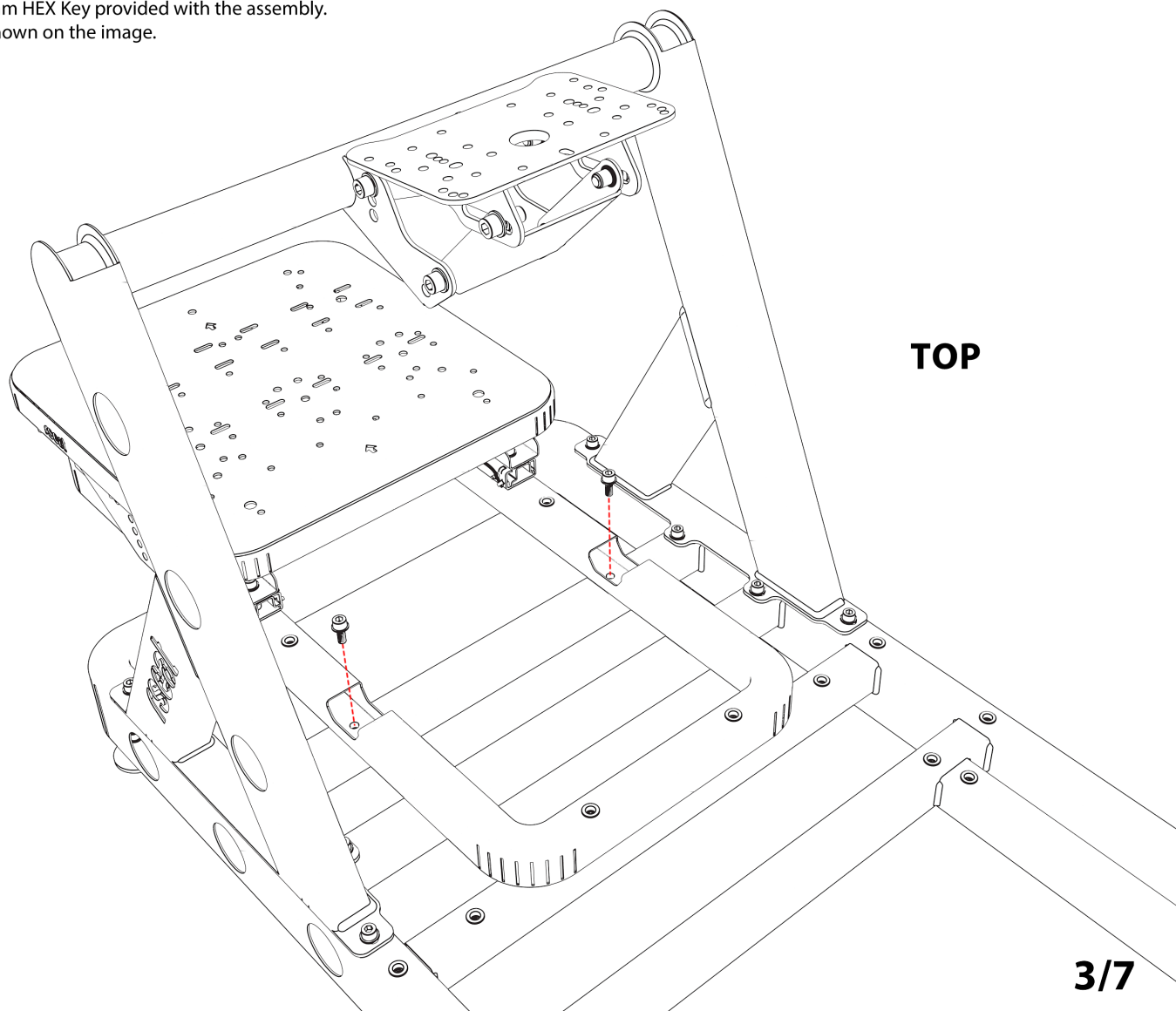

Install the Pedal Assembly mounting brackets (6) to the chassis (2) (red lines) using 4 x (M8 x 20mm) screws.
Fix the Pedal Assembly (3) to mounting brackets (6) (blue lines) with 2 x (M8 x 20mm) screws.
Use the 6mm HEX Key

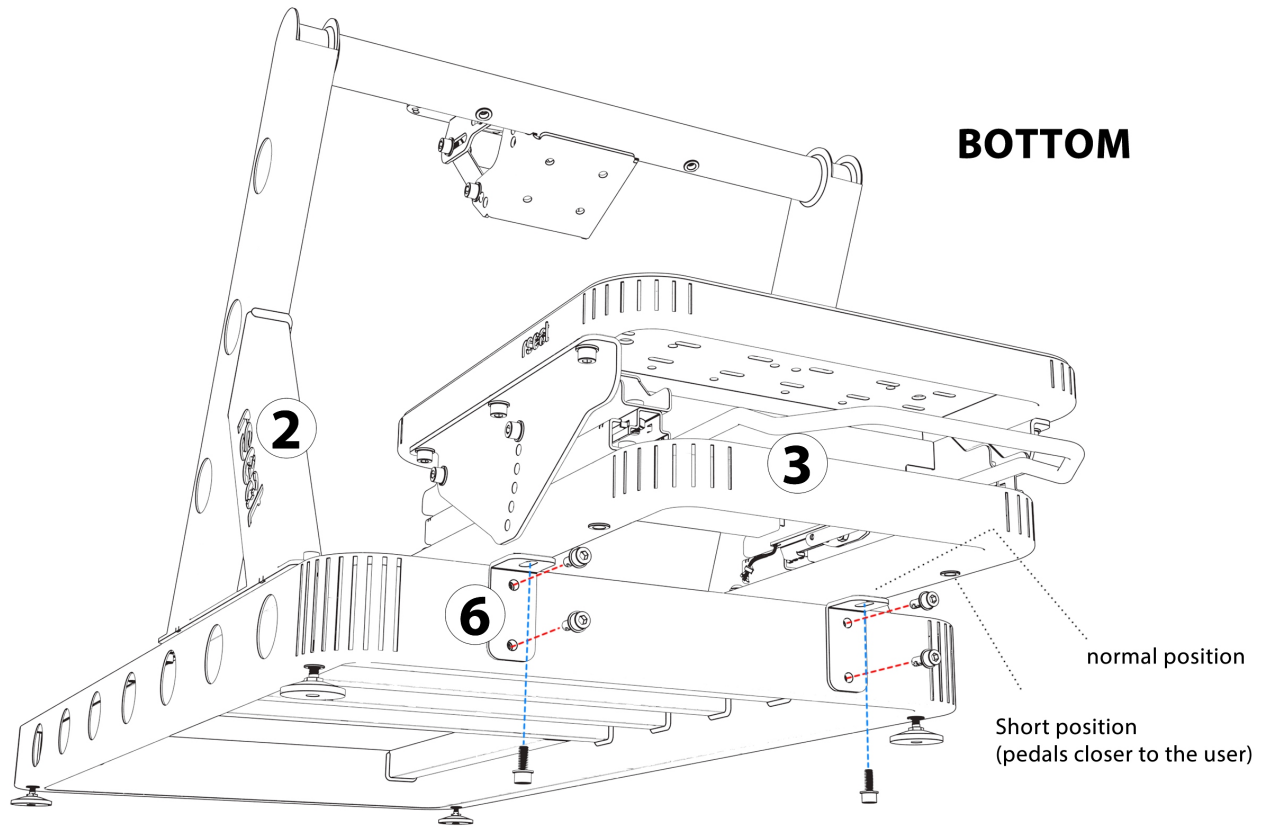

Slide the Pedal Assembly aluminum cover under pedal mounting plate and secure with 4 x (M8 x 20mm) screws.
Use the 6mm HEX Key

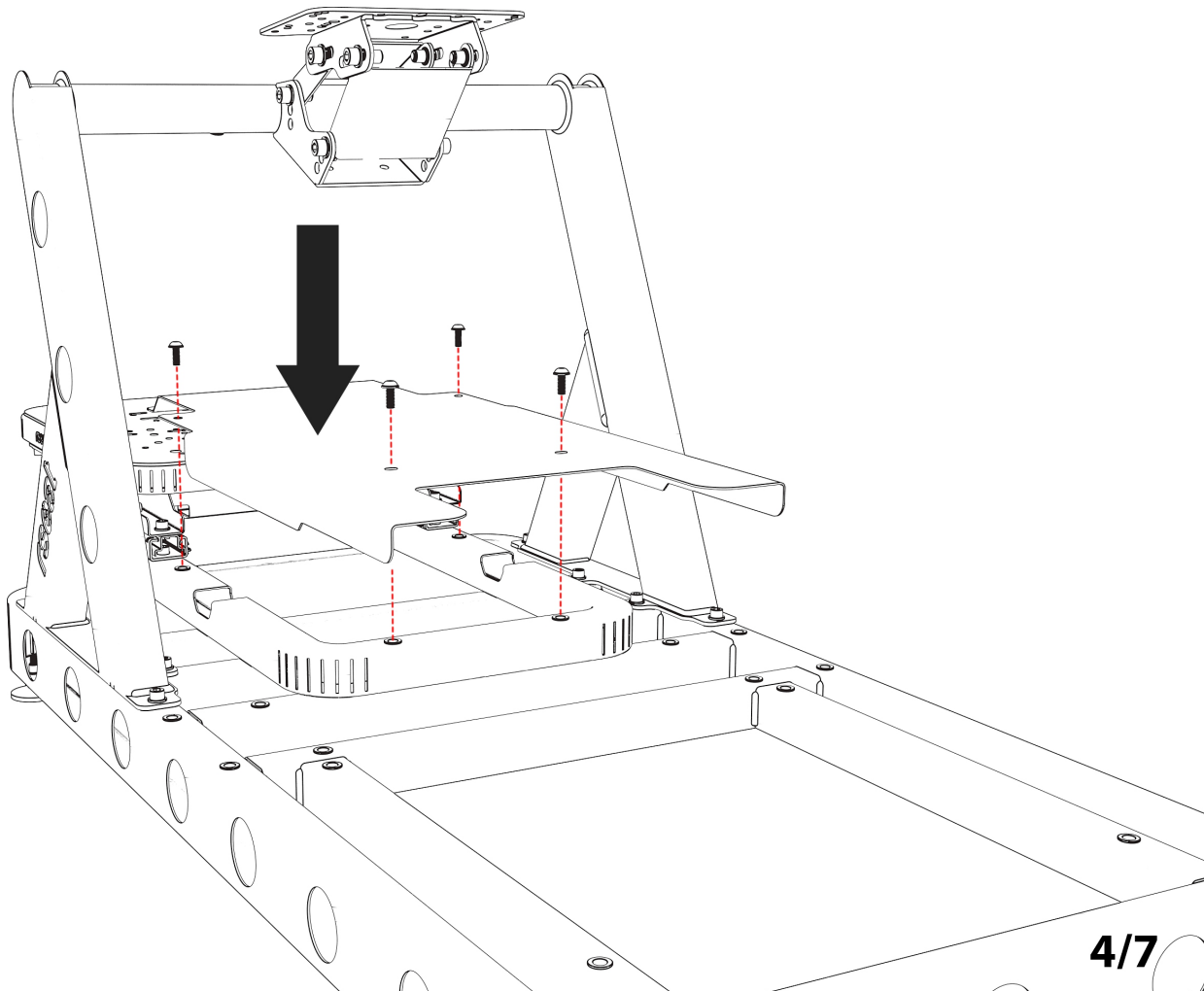

- 5** Install Seat Mounting assembly (4) to chassis (2)
Use 4 x M8 x 20mm screws (2 per side) with the 6mm HEX Key

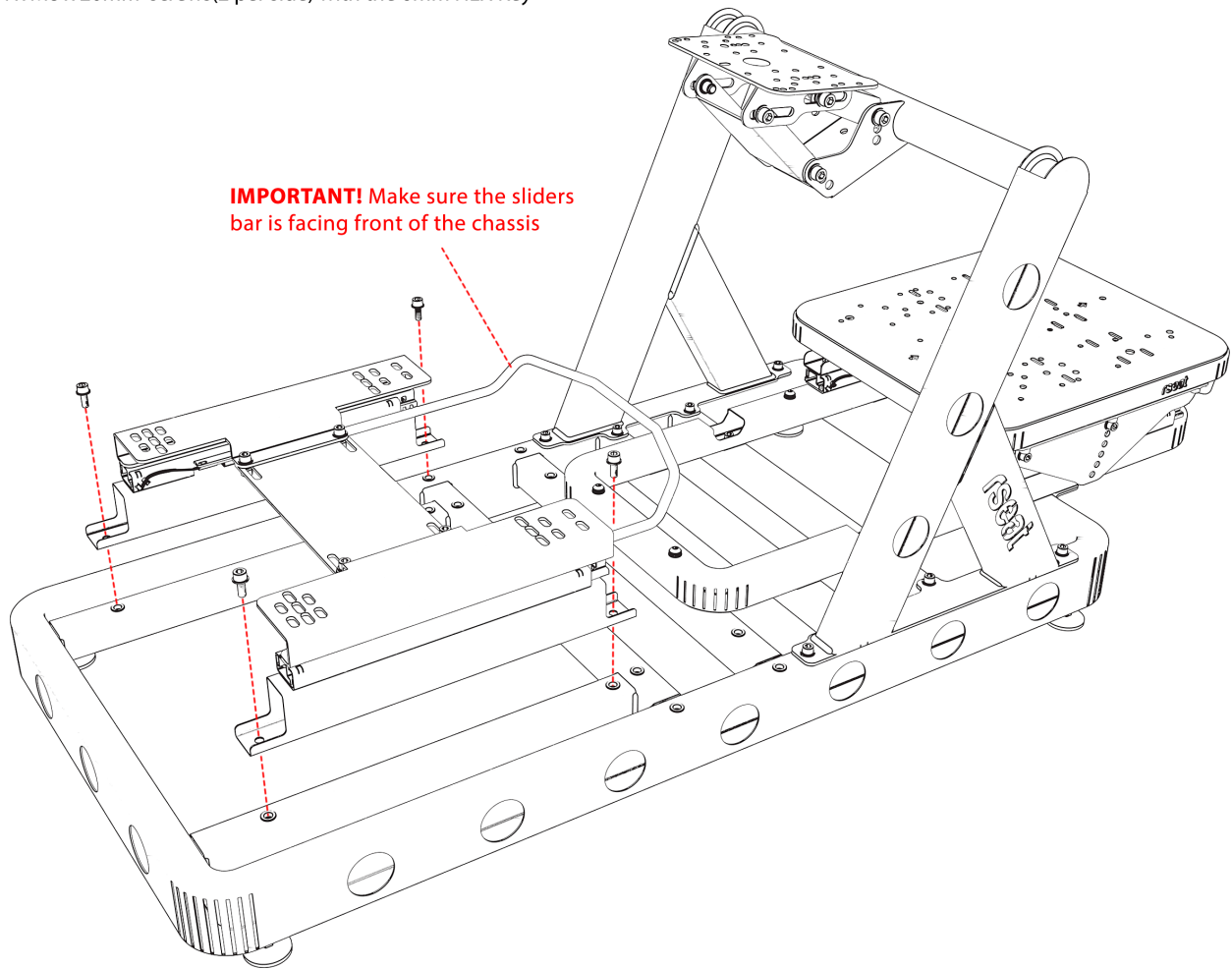

- 6** Install Seat (1) to Seat mounting brackets (5)
Use 4 screws (M8 x 25mm) (2 per side) with the 6mm HEX Key provided with the assembly.
IMPORTANT! Do not tight the seat yet. Only on hand!

IMPORTANT! Make sure the six holes are facing front of the seat

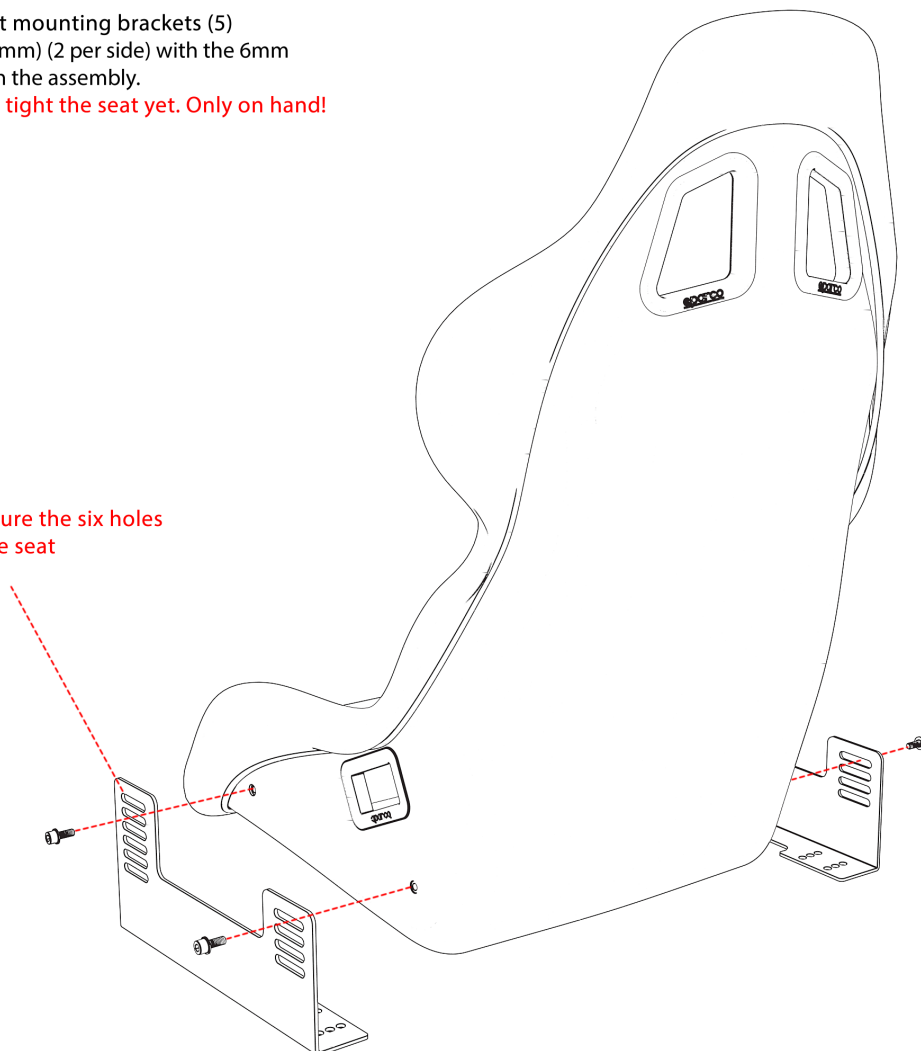

- 7** Install Seat (1) with Seat mounting brackets (5) to seat mounting assembly (4)
Use 4 screws (M8 x 20mm - Hexagon head) (2 per side) and 4 nuts (M8)
Use two 13mm wrenches, one to hold the bolt and one to tight the nut.

IMPORTANT! Align the seat with brackets (5)
to the center of the seat mounting assembly (4)

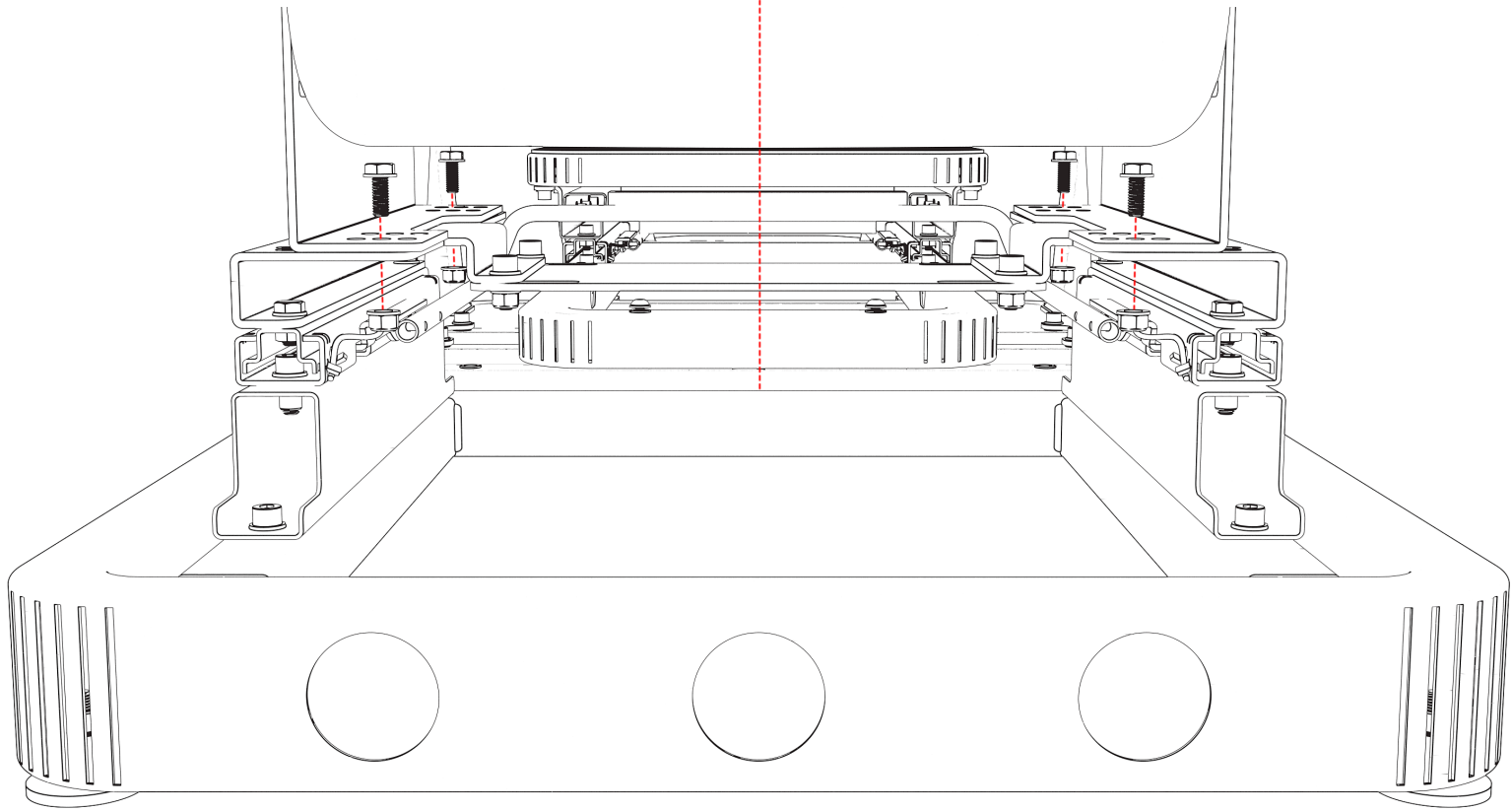

Now adjust the seat position to seat mounting bracket (5) - (height, tilt)
and tight the seat using the 6mm HEX Key provided with the assembly.

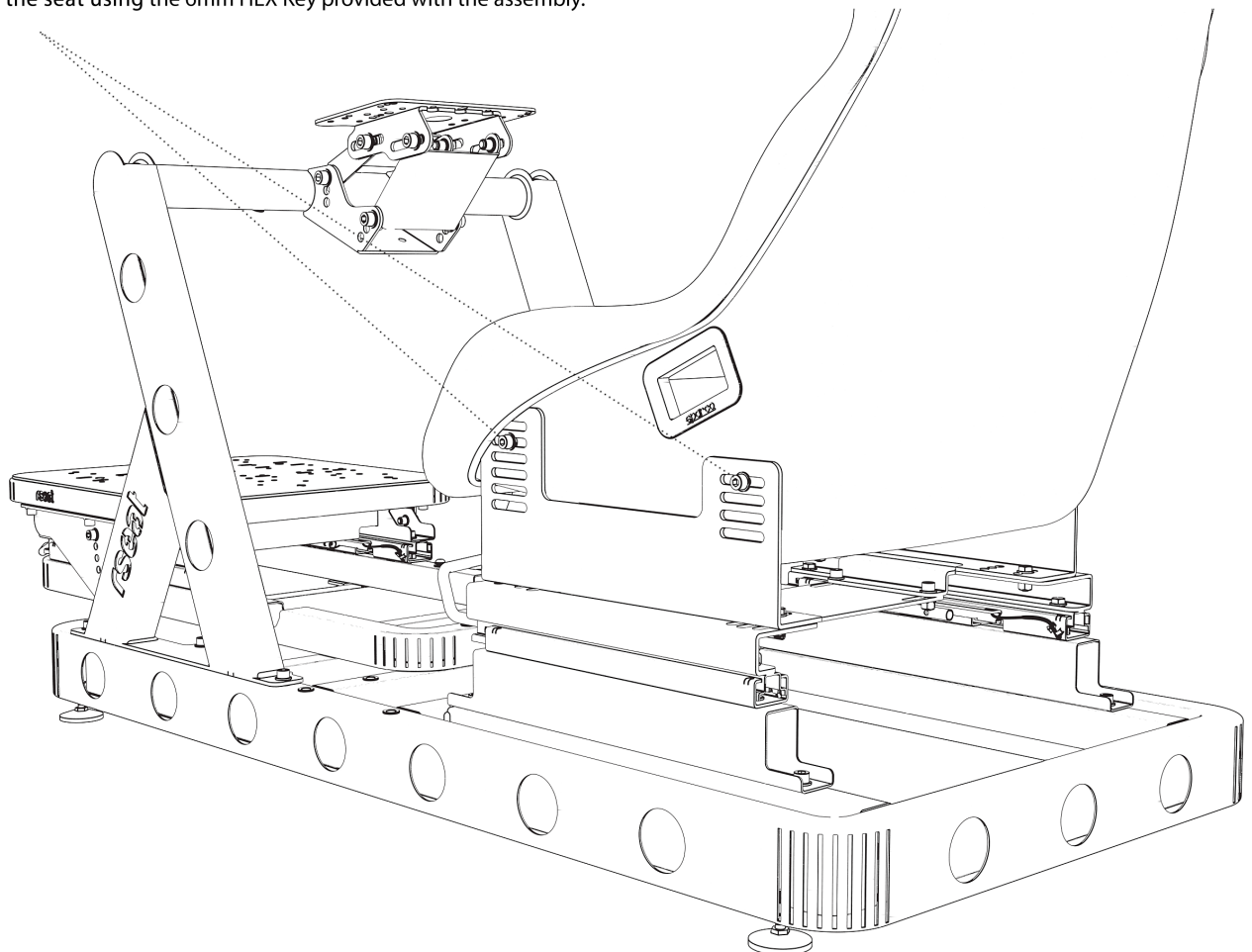

Your RSEAT B1 chassis is ready for wheel, pedals, upgrade kits (if any) installation.

8 RSEAT B1 ADJUSTMENT

- 1 To Adjust the wheel position use the 8mm HEX Key
- 2 To adjust the pedals angle use the 6mm HEX Key.
- 3 To Adjust the seat position use the 6mm HEX Key.
- 4 Seat slider bar. Pull-up and slide the seat front-back
- 5 Pedals slider bar. Pull-up and slide the pedals front-back
- 6 Adjust the B1 chassis level. Use 10mm wrench to level with the floor

